

10 JOULE XENON BEACONS for Harsh Industrial & Marine Environments XB13 Range

**IP66/67
Weatherproof**
**Corrosion Free
GRP/Polycarbonate**



Introduction

This range of ruggedised, weatherproof beacons, has been designed with high ingress protection to cope with harsh environmental conditions.

MEDC can also provide a range of beacons suitable for use in potentially explosive atmospheres.

For more information, refer to the catalogue or contact MEDC.

- ★ Weatherproof.
- ★ IP66 & IP67.
- ★ Operating temperature -55°C to $+70^{\circ}\text{C}$.
- ★ Corrosion resistant red painted GRP body.
- ★ High intensity flash.
- ★ Polycarbonate lens, various colours available.
- ★ Retained stainless steel cover screws.
- ★ Optional lens guard.
- ★ Optional telephone or relay initiate.
- ★ 3 x M20 cable entries.
- ★ Replaceable tube.
- ★ Switchable dual flash.

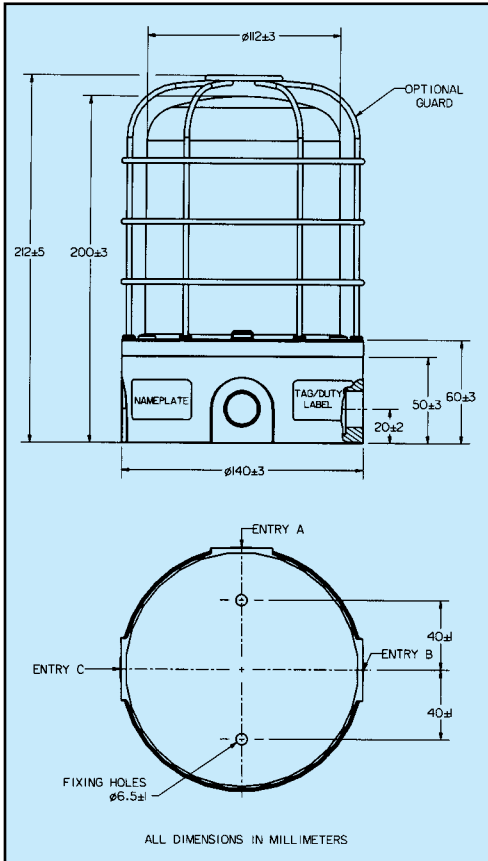

Specification

Material:	UV stable glass reinforced polyester body. UV stable polycarbonate cover/lens. Retained stainless steel cover screws.
Finish:	Painted red as standard or to Customer's specification.
Tube Energy:	10 Joules (second flash 7.5 Joules).
Weight:	1.1kg,
Operating Temperature:	-55°C to +70°C.
Ingress Protection:	IP66 & IP67.
Tube Life:	> 1 x 10 ⁶ flashes.
Voltage:	12V d.c., 24V d.c., 115V a.c., 230V a.c.

Current Consumption:	Voltage	Current Consumption
	12V d.c.	1.4A
	24V d.c.	650mA
	115V a.c.	180mA
	230V a.v.	100mA

Tube Type:	Xenon discharge.
Lens Colour:	Various colours available.
Terminals:	8 x 2.5mm ² .
Flash Rate:	1 flash per second.
Dual Flash Rate:	Time between dual flashes = 0.5 seconds. Charging time = 1 second. Cycle repeats every 1.5 seconds.
Labels:	Duty and tag labels available.
Cable Entries:	Up to 3 x M20 via knockouts.
Intensity:	Effective intensity 220 Cd. Peak intensity 75,000 Cd. (Figures are for clear lens at 1Hz flash rate).

FOR COLOURED LENSES

Colour	Red	Blue	Amber	Green	Yellow
Multiplying Factor	0.15	0.12	0.51	0.49	0.86

Ordering Requirements

The following code is designed to help in the selection of the correct unit. Build up the reference number by inserting the code for each component into the appropriate box. **Standard products available ex-stock as follows:**

Product	Description
XB13024RNNR	Weatherproof, 10J, 24V d.c., red lens, painted red body.
XB13024ANNR	Weatherproof, 10J, 24V d.c., amber lens, painted red body.
XB13230RNNR	Weatherproof, 10J, 230V a.c., red lens, painted red body.
XB13230ANNR	Weatherproof, 10J, 230V a.c., amber lens, painted red body.

Unit Type	Voltage	Lens Colour	Lens Guard	Options	Unit Finish																																																
XB13																																																					
	<table border="1"> <thead> <tr> <th>Voltage</th> <th>Code</th> </tr> </thead> <tbody> <tr> <td>12V d.c.</td> <td>012</td> </tr> <tr> <td>24V d.c.</td> <td>024</td> </tr> <tr> <td>115V a.c.</td> <td>115</td> </tr> <tr> <td>230V a.c.</td> <td>230</td> </tr> </tbody> </table>	Voltage	Code	12V d.c.	012	24V d.c.	024	115V a.c.	115	230V a.c.	230	<table border="1"> <thead> <tr> <th>Colour</th> <th>Code</th> </tr> </thead> <tbody> <tr> <td>Red</td> <td>R</td> </tr> <tr> <td>Blue</td> <td>B</td> </tr> <tr> <td>Green</td> <td>G</td> </tr> <tr> <td>Yellow</td> <td>Y</td> </tr> <tr> <td>Amber</td> <td>A</td> </tr> <tr> <td>Clear</td> <td>C</td> </tr> </tbody> </table>	Colour	Code	Red	R	Blue	B	Green	G	Yellow	Y	Amber	A	Clear	C	<table border="1"> <thead> <tr> <th>Guard</th> <th>Code</th> </tr> </thead> <tbody> <tr> <td>Yes</td> <td>Y</td> </tr> <tr> <td>None</td> <td>N</td> </tr> </tbody> </table>	Guard	Code	Yes	Y	None	N	<table border="1"> <thead> <tr> <th>Option</th> <th>Code</th> </tr> </thead> <tbody> <tr> <td>Duty</td> <td>D*</td> </tr> <tr> <td>Tag</td> <td>T*</td> </tr> <tr> <td>Telephone Initiate</td> <td>I</td> </tr> <tr> <td>Relay Initiate</td> <td>R</td> </tr> <tr> <td>None</td> <td>N</td> </tr> </tbody> </table> <p>*Please specify wording</p>	Option	Code	Duty	D*	Tag	T*	Telephone Initiate	I	Relay Initiate	R	None	N	<table border="1"> <thead> <tr> <th>Colour</th> <th>Code</th> </tr> </thead> <tbody> <tr> <td>Painted Red</td> <td>R</td> </tr> <tr> <td>Special</td> <td>S*</td> </tr> </tbody> </table> <p>*Please specify</p>	Colour	Code	Painted Red	R	Special	S*
Voltage	Code																																																				
12V d.c.	012																																																				
24V d.c.	024																																																				
115V a.c.	115																																																				
230V a.c.	230																																																				
Colour	Code																																																				
Red	R																																																				
Blue	B																																																				
Green	G																																																				
Yellow	Y																																																				
Amber	A																																																				
Clear	C																																																				
Guard	Code																																																				
Yes	Y																																																				
None	N																																																				
Option	Code																																																				
Duty	D*																																																				
Tag	T*																																																				
Telephone Initiate	I																																																				
Relay Initiate	R																																																				
None	N																																																				
Colour	Code																																																				
Painted Red	R																																																				
Special	S*																																																				



All the above specifications, dimensions, weights and tolerances are nominal (typical) and MEDC reserve the right to vary all data without prior notice. No liability is accepted for any consequence of use.